

LyoConstellation™ S80

Production Lyophilizer



Key Features

- Powerful, configurable, aseptic production freeze dryer with optional SP Hull Row-by-Row (RxR-36) loading system
- Range of telemetry options to fit Line of Sight™ approach enabling easy transfer of cycles
- Optional LyoFlux* 200 TDLAS instrument to measure vapor mass flow, mass flow, and infer critical process data
- Optional ControlLyo® Nucleation Technology for improved product homogeneity and process efficiency
- Optional Tempris* for wireless temperature sensing

Specifications

Lowest Shelf Temperature	-55 °C
Shelf Temperature Control Range	-50 °C to +50 °C
Shelf Temperature Control Accuracy At Shelf Inlet Manifold	-40 °C to +40 °C: ± 0.5 °C Outside this range: ± 1.0 °C
Shelf Pull-Down From 20 °C To -40 °C	≤ 60 minutes
Shelf Temperature Uniformity ¹	± 1.0°C
Lowest Condenser Temperature	-65 °C
Condenser Capacity	80 L
Condenser Pull-Down From 20 °C To -45 °C	≤ 60 minutes
Condenser Deposition Rate	100 L/24 hour
Compressor Horsepower	14.9 kW (20 hp)
System Refrigerant	R507b – GWP 3,985
Vacuum Rate Of Rise ²	≤ 30 mTorr/hour
Volume-Based Leak Rate ²	≤ 15 mTorr-L/sec (0.02 mbar-L/sec)
Lowest System Vacuum ²	≤ 20 mTorr

Note: Performance specifications are based on SP test data from clean, dry and empty (CDE) units operating at an ambient room temperature of approximately 20 °C. SP recommends an optimum operating range of 15-25 °C (59-77 °F) with an RH of ≤ 80 % at sea level.

Electrical Requirements

Voltage	208 VAC	400 VAC	480 VAC
Hertz	60 Hz	50 Hz	60 Hz
Phase	3 Φ (4 wire)	3 Φ (5 wire)	3 Φ (4 wire)
Breaker Amperage	275 A	150 A	125 A

ControlLyo® Requirements (Optional)

Volume To Vent Percentage Ratio (V _v /V _R)	< 6.5 %
---	---------

Note: Vent Volume (V_v) is the product chamber volume multiplied by 10. The volume of a standard LyoConstellation S80 chamber is 150 ft³ (4.24 m³). V_R is the volume of the room in which the lyophilizer is located.

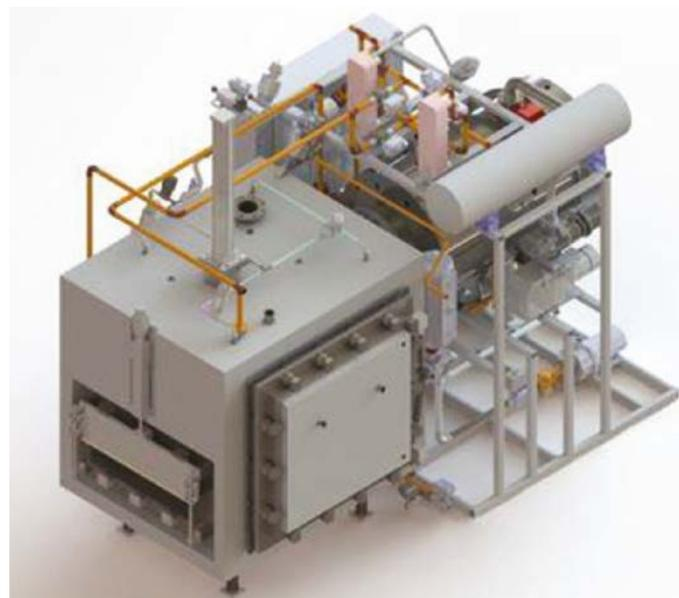

SP Hull LyoConstellation S80

Utility Requirements

Compressed Air	5.52-6.89 barg (80–100 psig)
Cooling Water ³	189.3 Lpm @ 26.6 °C (50 gpm max @ 80 °F)
Chamber Cooling Water	94.6-378.5 Lpm (25-100 gpm)
Inert Gas For Backfilling	9.3 Lpm @ 0.344-2.06 barg (0.33 scfm @ 5-30 psig)
Inert Gas For VLC / Vacuum Release	368 Lpm @ 0.344-2.06 barg (13 scfm @ 5-30 psig)
Inert Gas Consumption (Full Vacuum Release)	5,235 L @ 1 ATM
Inert Gas For ControlLyo®	2.41-2.75 barg (35-40 psig)
Steam For Sterilization In Place (SIP)	204 kg/hour (450 lbs/hour) @ 1.38–1.72 barg (20-25 psig)
Clean In Place (CIP) Water/Media	189 Lpm (50 gpm) @ 2.75 barg (40 psig)
Heat Output (Machine Room), Peak	0.732 kW/hour (2,500 BTU)

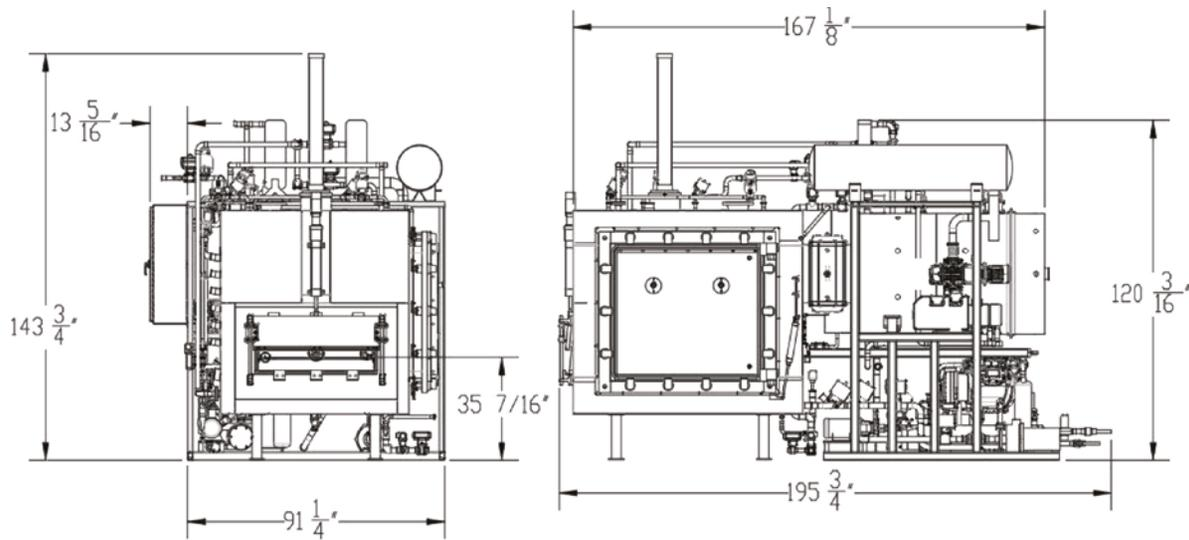

Dimensional Data

Width	2.7 m (106.3 in)
Length	4.97 m (195.75 in)
Height	3.05 m (120.19 in)
Height Incl Stoppering Ram	3.65 m (143.75 in)
Maximum Weight	9,185 kg (20,250 lb)

Note: LyoFlux™ TDLAS installation increases overall length by 915 mm (36 in). SP recommends a 36 in (915 mm) clearance around all sides of the unit for serviceability.

Materials of Construction

Product Chamber	AISI 316L stainless steel
Shelf	AISI 316L stainless steel
Condenser Chamber	AISI 316L stainless steel
Isolation Valve Disc	AISI 316L stainless steel

Surface Finish

Product Chamber Interior	Ra 0.635 micrometers (25 micro-inches)
Shelves	Ra 0.635 micrometers (25 micro-inches)
Condenser Chamber Interior	Ra 0.813 micrometers (32 micro-inches)

Additional Information

Stoppering	Top-down hydraulic 15 psig (1.03 barg)
Condenser Defrost Type	Hot water / steam (optional)
Noise Level ⁴	≤ 85 dB
Vapor Port Inner Diameter	20 in (508 mm)
Loading / Unloading Door To Cleanroom	Automatic / Autolocking
Chamber Inspection Door To Machine Room	Manual locking
Locking For Condenser Door	Manual locking
Protection Rating	IP2
CE Compliant	

Shelf Configuration

Number of Shelves	Shelf Area	Shelf Clearance
8 Shelves (7 Usable, 1 Radiant)	7.8 m ² (84 ft ²)	121 mm (4.75 in)
Usable Shelf Dimensions (W × L)	914.4 mm × 1912.2 mm (36 in × 48 in)	—
Shelf Loading Height	900 mm (35 1/16 in)	—

Refrigeration Information

F Gas	R507b
Charge (Kg)	Approximatley 65 lbs
GWP	3,985
Total CO ₂ e (tonnes)	90.61

Options/Other Considerations

Rotary Hull Isolation Valve
ControLyo® Nucleation Technology
N+1 Redundancy
LyoFlux® 200 TDLAS Mass Flow Sensor
Independent CIP Skid
Tempris® Wireless Temperature Sensors
Virtual Servers & Thin Clients

¹ Shelf temperature deviations shall not exceed the specification relative to the mean of the highest and lowest temperature readings

² Vacuum specifications are based on SP test data from similar units equipped with a two-stage rotary vane vacuum pump. Units equipped with other vacuum pumps may yield different results (e.g. a dry pump shall yield a Lowest System Vacuum of ≤ 50 mTorr)

³ Cooling water temperatures should not exceed 26.6 °C (80 °F) supply; 32.2 °C (90 °F) return

⁴ Noise from the equipment under normal operating conditions shall not exceed 85 dB when measured at any point 91.5 cm (36 in) away from the equipment. Lyophilizers equipped with ControLyo® shall exceed the specified noise level rating for approximately 3 to 5 seconds during depressurization and SP recommends the use of both hearing and eye protection during the ControLyo® process